

POWERCART H SERIES

The PowerCart H-Series is a compact, highly maneuverable industrial cart mover. The PCH combines the hydraulic lift system of a manual jack with a unique, quick-connect hitch system *and* the POWERPALLET 2000 drive system...together creating a fast, powerful, easy-to-use and highly maneuverable cart mover.

Connecting via the custom mating cart hitch, (one hitch attached to each cart) it allows a single operator to effortlessly move wheeled loads weighing up to 3,000lbs.



Worldwide Patent Pending



Multiple Speed Options and Safety Bump Stop



180° turn radius

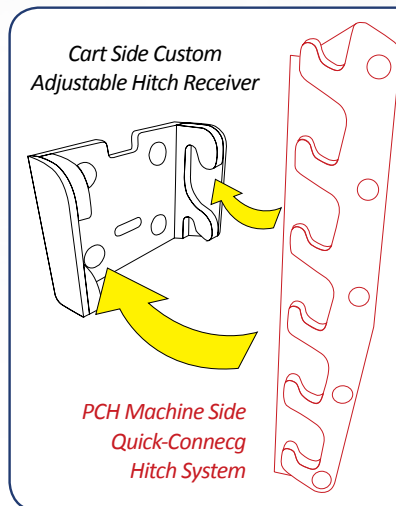

The PCH can be customized to fit nearly any type of industrial cart out there using it's patent pended, quick connect -hitch system!

AMS, INC.

10030 Via de la Amistad San Diego CA 92154, United States
☎ +1 619-661-5985 📠 +1 619-661-5995 @ams@ams-fa.com

AMS de MEXICO

Polígono Buenavista -- Calle Cementera Lote 9, Mz 8 Ejido Buenavista - Querétaro, Qro. 76225
☎ +52 442-312-0920 @mexico@ams-fa.com

AMS do BRASIL

AMS Do Brasil Automacao Industrial LTDA
☎ +55 19-2511-4943 @quote@ams-fa.com

POWERCART H-SERIES TECHNICAL BRIEF

POWERCART H-Series Specs	Max. Speed*		Load Moving Capacity		Drive Motor	Li-Ion Battery Pack		Recharge Time
	M/Min	MPH	Kg	Pounds		Amp Hours	Voltage	
	100	3.7	1,600	3,000	Brushless DC	5Ah	51.8	2 Hours (from 80% depletion)

WHY THE POWERCART H-SERIES?

FASTER: The POWERCART H-Series (PCH) features a self-aligning quick-connect/disconnect hitching system. Additionally, it features a user settable max. speed of 3.7mph (100m/min) and infinitely variable throttle for both forward (pushing) and reverse (pulling).

MORE POWERFUL: Utilizing the same drive system as on the POWERPALLET 2000, the PCH can move 3,000lb (1,360 kg) with ease, or for loads weighing even more, it becomes a powered assist that does most of the heavy lifting.

MORE MANEUVERABLE: With more than 180° of directional rotation at the hitch and a footprint less than 11" (275mm) wide at full turn, the PCH offers exceptional maneuverability in tight spaces. Additionally, the PCH is intuitive and easy-to-use either pulling or pushing loads.

MORE FLEXIBLE: The PCH employs a unique spring compliance system for hitching. The operator can engage but only lift enough to compress the spring and provide traction, or pump more and lift the hitched end of the cart entirely off the ground. This is ideal for two-wheeled / two-legged carts, poorly running carts or for operation on uneven / low-traction floors.

SAFER TO USE: A unique feature of the PCH is its automatic pin locking system that ensures a secure connection between cart and mover. A spring-loaded pin locks the PCH's hitch to the cart's hitch preventing the two from separating - regardless of the terrain or use case. The locking pin is also automatically retracted when the cart is unhitched.



The cart hitch can be mounted on any wheeled cart

Quick charge Li-Ion battery pack and charger

*Worldwide Patent Pending

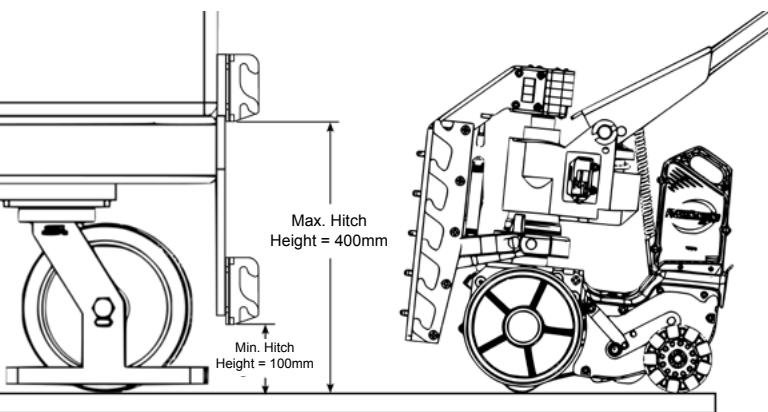

BETTER VALUE: Despite the exceptional performance, features and reliability, the PCH costs less than most movers in its class. The PCH and PP2K share not just the same operating method, but also the same key components (including operator controls, battery packs and chargers), *these two series are perfect partners in facilities that utilize both carts and pallets.*